

LED BEACONS

CLASS I, CLASS II

FROM GROTE



12
FLASH
PATTERNS

SAE
INTERNATIONAL
SAE J845™
STANDARD

S
S-LINK™
CAPABLE

5-YEAR
WARRANTY

VOLTAGE:
PERMANENT MOUNT: 12–24 VDC
VACUUM MAGNET MOUNT: 12 VDC
AMP DRAW:
0.5 AMPS @ 12 VDC
APPROVALS:
SAE J845 CLASS I (AMBER, WHITE, RED)
SAE J845 CLASS II (BLUE)
NOT SAE APPROVED (GREEN)

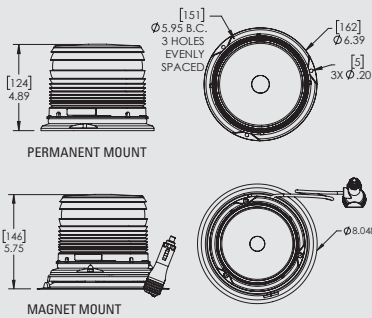

S-Link System is a proprietary technology that will allow similar S-Link products to be synchronized. This would allow for a user to define the flash patterns on multiple devices for a customized, tailored look on a vehicle.

Note: Only S-Link compatible products can be synchronized together. Refer to user installation manuals for details on S-Link Synchronization.

LED BEACONS WITH S-LINK SYNCHRONIZATION

These LED beacons are designed to provide optimal lighting for all application needs. Popular with vehicles in the Agriculture, Mining, Towing, Utility and Construction industries, users can define the flash patterns on multiple devices for a customized lighting solution.

FEATURES & BENEFITS

- 12 different selectable flash patterns in either of two phases, plus steady-on
- Extremely low current draw; Circuit board is conformal coated to protect circuitry
- Durable polycarbonate twist on/off lens
- S-Link™ System synchronizing capabilities with up to six other units (for hardwire models only); allows for synchronization with other S-Link compatible products
- Durable, lightweight polycarbonate base, flange 3-hole permanent mount, 1" pipe mount, vacuum magnet w/aux. plug (on/off and pattern select switch)
- 5-year warranty

PART #	DESCRIPTION	MOUNT	COLOR
SHORT LENS			
78031	LED BEACON, CLASS I, SHORT LENS	PERMANENT	○ WHITE
78041	LED BEACON, CLASS I, SHORT LENS	VACUUM MAGNET	○ WHITE
78033	LED BEACON, CLASS I, SHORT LENS	PERMANENT	● AMBER
78043	LED BEACON, CLASS I, SHORT LENS	VACUUM MAGNET	● AMBER
78035	LED BEACON, CLASS II, SHORT LENS	PERMANENT	● BLUE
78045	LED BEACON, CLASS II, SHORT LENS	VACUUM MAGNET	● BLUE
78034	LED BEACON, SHORT LENS	PERMANENT	● GREEN
78032	LED BEACON, CLASS I SHORT LENS	PERMANENT	● RED
78030	LED BEACON, CLASS I SHORT, CLEAR LENS	PERMANENT	● AMBER
TALL LENS			
78051	LED BEACON, CLASS I, TALL LENS	PERMANENT	○ WHITE
78053	LED BEACON, CLASS I, TALL LENS	PERMANENT	● AMBER
78055	LED BEACON, CLASS II, TALL LENS	PERMANENT	● BLUE
78054	LED BEACON, TALL LENS	PERMANENT	● GREEN
78052	LED BEACON, CLASS I, TALL LENS	PERMANENT	● RED
78050	LED BEACON, CLASS I, TALL, CLEAR LENS	PERMANENT	● AMBER



EZ-FIND
SCAN FOR TECH SPECS,
RELATED PRODUCTS
AND MORE

**FOR MORE INFORMATION
VISIT OUR WEBSITE.
GROTE.COM**

