

WHITE NOISE BACKUP ALARMS FROM GROTE



12/24V

DUAL
VOLTAGE

SAE
INTERNATIONAL

MEETS OR
EXCEEDS



DURABLE
CONSTRUCTION



WHITE
NOISE

VOLTAGE: 12–24 VDC
AMP DRAW (73340, 73450, 73470): 0.4A @ 14VDC
AMP DRAW (73460): 0.16A @ 14VDC
MATERIAL: GLASS FILLED NYLON
OPERATING TEMPERATURE: -40°C TO +85°C

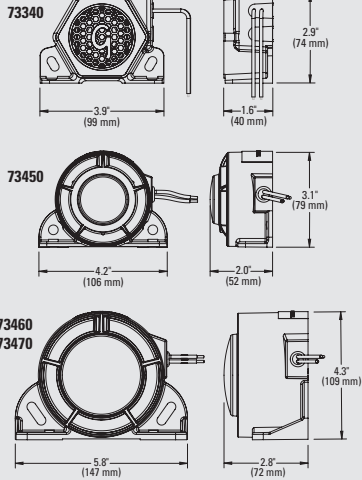

REDUCE NOISE POLLUTION WITHOUT COMPROMISING SAFETY

Grote’s “White Noise” backup alarms address concerns associated with traditional tonal alarms in busy work areas. By emitting sound across multiple frequencies, these alarms help to tackle noise pollution.

This design ensures individuals in the danger zone around reversing vehicles are adequately warned, while keeping overall noise levels in check. This makes them an ideal choice for bustling work environments.

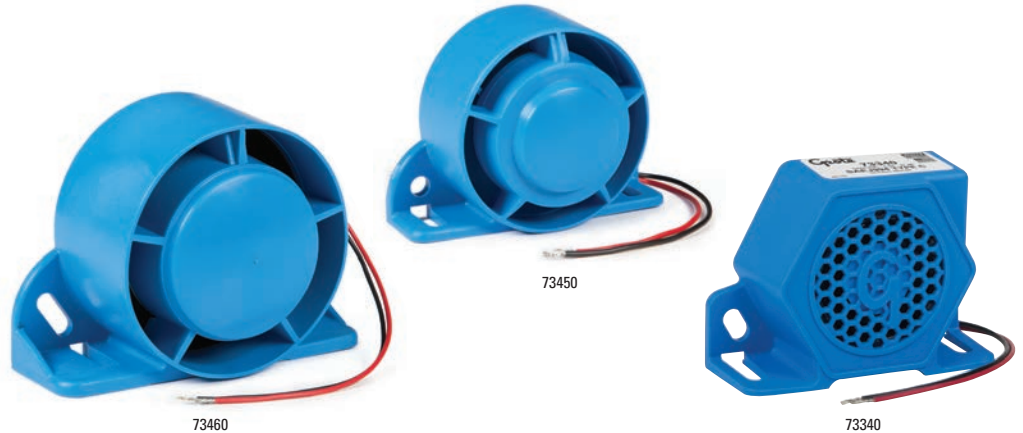

FEATURES & BENEFITS

- White Noise alarms help to reduce noise pollution (ideal for use in residential areas)
- Rugged construction which features glass-filled nylon housings
- Universal mounting options for simple installation and replacement
- Rear facing design provides protection for the speaker from the elements ensuring durability

			APPROVALS
73340	BACKUP ALARM, MULTI FREQUENCY, “WHITE NOISE”, STANDARD MOUNT	97 dB	SAE J994 TYPE C
73450	BACKUP ALARM, MULTI FREQUENCY, “WHITE NOISE”, REVERSE MOUNT	97 dB	SAE J994 TYPE C
73460	BACKUP ALARM, MULTI FREQUENCY, “WHITE NOISE”, REVERSE MOUNT	102 dB	SAE J994 TYPE F
73470	BACKUP ALARM, MULTI FREQUENCY, “WHITE NOISE”, REVERSE MOUNT	107 dB	SAE J994 TYPE A



White Noise Backup Alarms prioritize safety without causing unnecessary disturbance to those nearby the work site.



EZ-FIND
 SCAN FOR TECH SPECS,
 RELATED PRODUCTS
 AND MORE

**FOR MORE INFORMATION
 VISIT OUR WEBSITE.
 GROTE.COM**

